

P/N: RE-C-TF-003

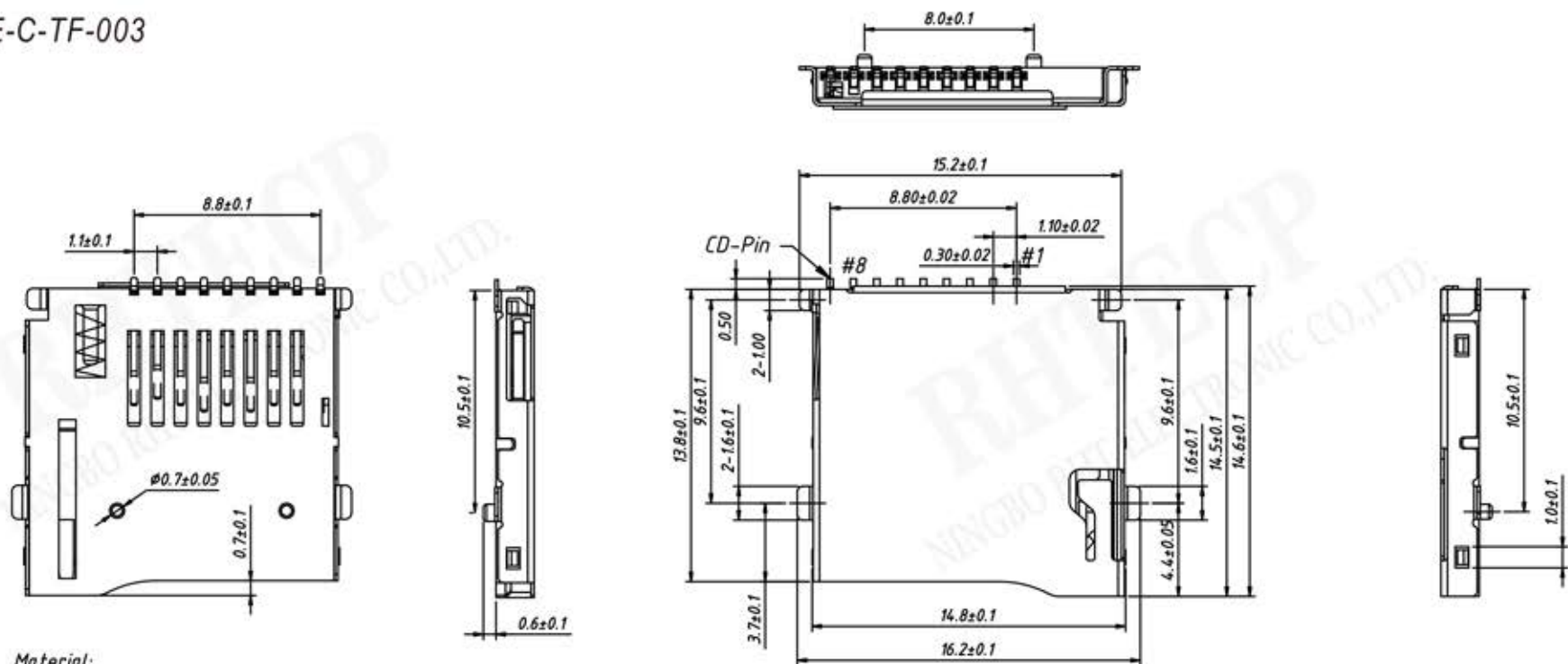

Material:

Insulator: High Temperature Thermoplastic, UL 94 V-0.

Contact: Copper Alloy T=0.15, Plated 50u" Ni Overall. Plated Au Selective Contact Area Plated 30u"~70u" Sn Over Ni On Solder Area.

Shell: T=0.15, Plated 30u" Ni Overall min. Plated 0.5u" Au Selective Contact Area

Electrical:

Current Rating: 0.5 A

Voltage Rating: 3.3V

Ambient Temperature Range: -25°C ~ +85°C

Storage Temperature Range: -25°C ~ +85°C

Ambient Humidity Range: 95% R.H. Max.

Contact Resistance: 100mΩ Max.

Insulation Resistance: 1000MΩ Min./500VDC

Mating Cycles: 5000 Insertions.

Peak temperature: 260°C ±0.5°C

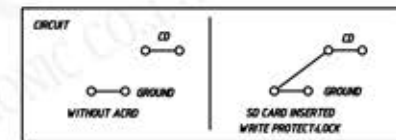
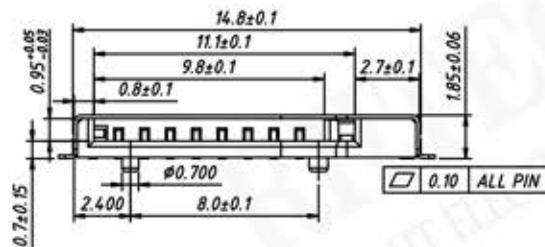

P/N: RE-C-TF-003

T-Flash Card Insert Drawing:

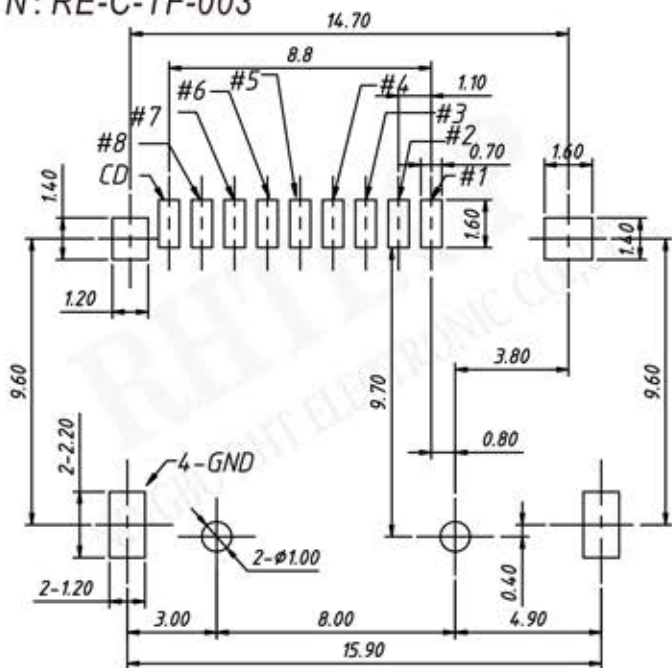

PIN NO.	PIN ASSIGNMENT
1 #	DAT2
2 #	CD/DAT3
3 #	CMD
4 #	VDD
5 #	CLK
6 #	VSS
7 #	DAT0
8 #	DAT1
9 #	CD

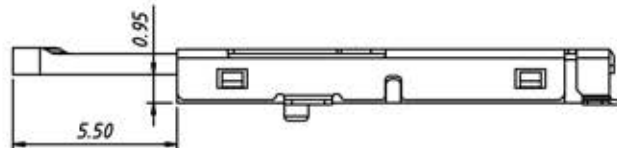
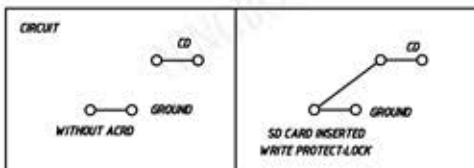

Micro SD Card-Un Lock

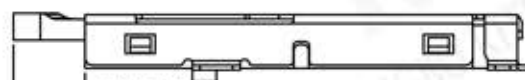

Micro SD Card-Lock



Micro SD Card-Push

