

Dimensions (Unit:mm)

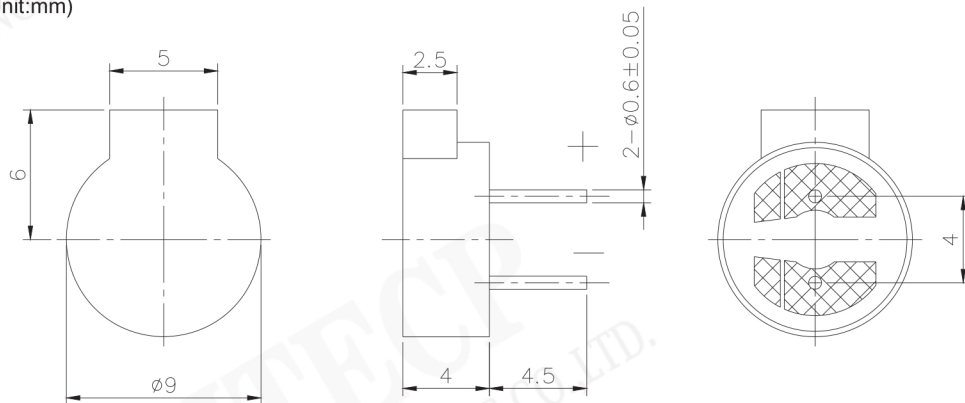

Magnetic Transducer Buzzer Series

RE-B-MT-09*04S $\phi 9 \times 4$ mm Magnetic Transducer Buzzer Series

SPECIFICATIONS

Rated Voltage:	1.5V
Operating Voltage:	1-3V
Max. Rated Current:	80mA
Min. S.P.L. (@ 10cm):	85dB
Coil Resistance:	$5.5 \pm 1 \Omega$
Resonant Frequency:	2730Hz
Operating Temp:	-20 ~ +70°C
Weight:	0.7g

ORDER INFORMATION

Product NO.: RE-B- MT - 09*04 - A



Order Code	Rated Voltage	Max. Rated Current	Coil Resistance	Min. S.P.L. (@10cm)	Operating Voltage
RE-B-MT-09*04-A	1.5V	15mA	$27 \pm 3 \Omega$	80dB	1...2V
RE-B-MT-09*04-B	5V	40mA	$50 \pm 5 \Omega$	85dB	4...8V
RE-B-MT-09*04-C	12V	40mA	$115 \pm 12 \Omega$	85dB	8...16V